

Molines – towards a responsive Web platform for flood forecasting and risk mitigation

João L. Gomes, Gonçalo Jesus,
João Rogeiro, Anabela Oliveira
Laboratório Nacional de
Engenharia Civil, Information
Technology in Water and
Environment Group, Av. do Brasil
101, 1700-066 Lisboa, Portugal
Email: {jlgomes, gjesus, jrogeiro,
aoliveira}@lnec.pt

Ricardo Tavares da Costa,
André B. Fortunato
Laboratório Nacional de
Engenharia Civil, Estuaries and
Coastal Zones Division, Av. do
Brasil 101, 1700-066 Lisboa,
Portugal
Email: {rcosta,
afortunato}@lnec.pt

□ **Abstract—** This paper presents an innovative real-time information system for enhanced support to flood risk emergency in urban and nearby coastal areas, targeting multiple users with distinct access privileges. The platform addresses several user requirements such as 1) fast, online access to relevant georeferenced information from wireless sensors, high-resolution forecasts and comprehensive risk analysis; and, 2) the ability for a two-way interaction with civil protection agents in the field. The platform adapts automatically and transparently to any device with data connection. Given its specific purpose, both data protection and tailored-to-purpose products are accounted for through user specific access roles. This paper presents the platform's overall architecture and the technologies adopted for server-side, focusing on communication with the front-end and with the wireless sensor network, and the user interface development, using state-of-the-art frameworks for cross-platform standardized development. The advantages of the adopted solution are demonstrated for the Tagus estuary inundation information system.

I. INTRODUCTION AND MOTIVATION

NATURAL and hydraulic structures related floods are severe threats to life and property. The main goal of flood risk management in aquatic environments is to reduce human losses and the damages related to floods, and should be supported by adequate hazard monitoring and timely early warning of the events.

Some of the world's most densely populated cities are located in estuarine low-lying areas facing thus a high risk of inundation with a potential for significant economic costs and the loss of lives. These areas are highly vulnerable due to the growing human activity in their margins. Simultaneously, the hazards in these environments are severe due to the combined effects of oceanic, atmospheric and river forcings. Furthermore, they are increasing due to the effects of climate change, such as sea level rise, growing storminess and more extreme river flows. Floods in estuaries

are associated to particular climatological conditions, namely very high tidal levels and large fresh-water discharges, or of high tides and storm surge conditions [1]. In addition to these progressive, slow phenomena, that are possible to predict a few days in advance, episodes of very intense and concentrated in time rainfall can lead to urban flooding in areas with insufficient drainage conditions and flash floods in small watershed tributaries to the estuary [2]. The effects of high water levels in estuaries can also be exacerbated by human interventions in the system, particularly in urban areas where drainage system behavior has to be considered.

Recently, the processes of prediction, detection, notification and population warning are becoming increasingly assured by automated systems, such as SAGE-B [3]. These information systems can be valuable assets for risk management, supporting all fundamental data related to flood events and the emergency elements needed for rescue in the predicted flooded areas. Unfortunately, most flood management systems still suffer from significant functional limitations, due to the difficulties in the access to monitoring data and unreliable, scattered, multiple sources of information, the use of inadequate flood forecasting due to inaccurate modeling tools, that either neglect relevant processes or are coarsely applied to the site at risk, and insufficient sharing of information across multiple emergency actors [4].

With the recent use of reliable automatic data acquisition systems and highly efficient and accurate numerical models, the most important constraints for the operational use of real-time information systems have been minimized, allowing for adequate forecasting of relevant events [5], [6]. The integration of these tools into interactive and flexible computational GIS-based platforms has paved the way to a change of paradigm in routine and emergency management of coastal resources and harbor operations [7], [8]. These platforms take advantage of novel technologies to provide on-line, intuitive and geographically-referenced access to real-time data and model predictions, and to produce on-demand services. However, much remains to be done on the interoperability between data providers and data consumers,

□ This work was funded by the Portuguese National Foundation for Science and Technology through project MOLINES (PTDC/AAG-MAA/2811/2012)

cross-platform and multiple users' flexibility and speed of access to data.

The project MOLINES (*Modelling floods in estuaries. From the hazard to the critical management*) aims at integrating existing and new wireless sensor networks, accurate model forecasts at both urban and estuarine scales and IT technology to create a Web platform that can contribute to a fast, coordinated mobilization of emergency agents and other managing entities for a timely response to inundation events in the Tagus estuary. The proposed platform is generic, interactive, facilitating the coordination between emergency agents and the individual contribution of civil protection agents in the field, and can be deployed elsewhere. It aims at contributing to a coordinated strategic planning and emergency response in urban and nearby estuarine regions, optimizing the alert to authorities, duly supported by real time monitoring and predictions of inundation.

This paper describes the platform, its architecture, and all innovative aspects related to the UI, product creation and choice of technologies. Besides this introduction, chapter 2 provides a background on IT technologies and platforms for real time information access, identifying the key aspects to be addressed. Chapter 3 presents the concept and implementation of the solution, focusing on requirements and technology choices. The application to the MOLINES case study is briefly presented in Chapter 4, and Chapter 5 closes the paper with some considerations for future work.

II. BACKGROUND

Technology is dramatically changing our ability to prepare for and respond to extreme events, facilitating the management of crisis incidents [9]. Information systems and technologies contribute to a better communication and action in complex systems, by helping in disaster response and in collecting information, analyzing it, sharing it, and timely disseminating it to the people at risk. In particular, timely information sharing amongst emergency actors is critical in emergency response operations [10]. Several research projects have been devoted to emergency and disasters management to create modelling and simulation techniques and tools for the emergency management. Relevant examples are the dynamic and adaptive models for operational risk management [11], [12].

Information technology is enhancing disaster management and communications through tools such as computer networks, virtual reality, remote sensing, GIS, and decision support systems. During the mitigation and preparation phases of an emergency the use of satellite communications and spatial analysis systems can be extremely valuable [13]. In recent years, many web-based emergency response systems have been developed and several studies shown the great complexities surrounding the design of this kind of systems [14]. Often, developments in other areas are overlooked and resources are spent looking

for a solution that has been already implemented and proved in other environments. An example of an IT system to manage emergency situations is the Global Disaster Information Network (GDIN www.state.gov/www/issues/relief/gdin.html). More elaborated examples with complex architectures, integrating geographic information systems, spatial databases and the internet are described in [15] and [16]. In [17] a WebGIS is presented addressing risk management related issues, providing authenticated users access to queryable information, depending on their authorization level. Hence, they achieve the goal of having a platform accessible anywhere with an internet connection, and multiple levels of access to different hierarchic roles. This is a similar approach to the one presented herein, except an existing tool has been adapted to the use-case, when compared with a tailored-made solution.

Building on these experiences and in the scope of several projects (INTERREG SPRES; FP7 Prepared), LNEC has been developing and applying a suite of Web platforms denoted as WIFF - Water Information Forecast Framework [7] to provide access to real time information to decision makers. These platforms were conceived for a single type of users and to provide full access to real time sensor data and model predictions, constituting at the same time a repository of past information, being available at each deployment site to the relevant end-users. For the SPRES platform, real time products were integrated with emergency planning information (hazard, vulnerability and risk maps as well as mitigation action sheets) to constitute a one-stop-shop for all data relevant to oil spill prevention and mitigation [7].

These platforms take advantage of novel technologies to provide on-line, intuitive and geographically-referenced access to real-time data and model predictions, and to produce on-demand services in support of routine management of coastal resources and harbor operations. Technology support include a) Drupal, a PHP-based Content Management System, to access model metadata, status and products, b) map server support (Geoserver) providing Web Map Services (WMS) to allow for geospatial placement of monitoring and forecast products, and model output query capabilities, and c) Flex, using the OpenScales library to handle geospatial information, for the WebGIS development.

However, the need for interaction between the multiple emergency actors and to have fast access to real time information (of both conventional data streams and on-the-fly in-the-field information during flood emergencies) from several users simultaneously, raises new requirements for these new platforms. Additionally, the new system should be cross-platform, i.e., to be built in a way that it is automatically and transparently adaptable to any device with a data connection, providing access to emergency information anywhere.

III. CONCEPT AND IMPLEMENTATION OF THE SOLUTION

The main goal for the platform described herein, is to provide a quick and responsive tool for flood risk forecast and assessment. End-users should be able to access information on the platform with no hassle and in any device from anywhere, providing that a data connection is available.

Moreover, since we are working directly with the civil protection agents as project partners, there is a major focus on developing on important issues for them. Specifically, our platform aims at fulfilling ease on usability and providing tools for quick decision taking by them, providing a product tailored for their needs. This tool is also being developed with modularity and reusability in mind, so that very little modifications to the platform code need to be made if the forecast product changes from “water levels” to other variables of interest. To achieve this, back and front-end are bind in such a way that the former provides access to the data while the front-end consumes (via a set of REST services) and displays the products without being content-aware, i.e., it shows data without considering data types. Since the front-end is not content-aware, a new instance of the platform, for visualizing and analyzing other types of data, can be created simply by changing the products made available by the back-end and performing basic adaptations to the front-end. Moreover, since the back-end serves data in a standard way (REST services), the front-end itself may also be substituted by another consuming service, be it a mobile application, a web-page or other data consuming service. This allows for interoperability between platforms, allowing other users to use these services straightforwardly, after being successfully authenticated and authorized.

This flow of information is illustrated in Fig. 1, where a separation of concepts, between back-end and front-end is clearly visible. The back-end consists of an instance of CakePHP, a MVC PHP framework, with a PostgreSQL storage database (with PostGIS extension), coupled with several instances of Geoserver and Perl and Python scripts.

The code developed with CakePHP handles user control and user accesses, based on access control lists and roles, and streamlines access to the database via REST requests from the front-end. Geoserver, an open source server for geospatial data sharing, manages the georeferenced imagery (both in raster and vector formats) and serves them using open standards, such as WMS. This also promotes interoperability by allowing that different systems exchange data with each-other using known standards. Geoserver uses data, both from the PostgreSQL/PostGIS database, but also from results produced by the flood prediction models, in the form of shapefiles, allowing for model results probing directly on the data served through the UI.

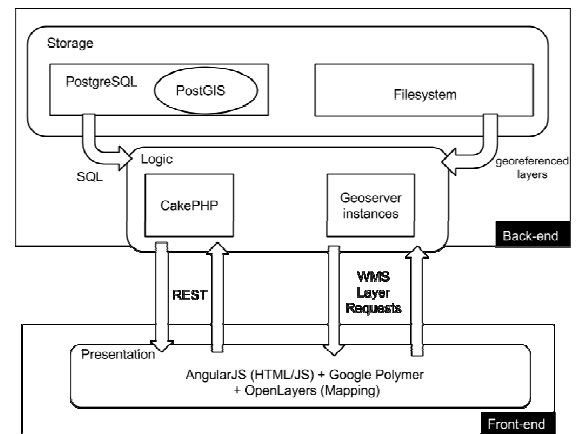

Fig. 1 Technological Architecture of the solution

Since a huge amount of requests are made to Geoserver, and it lags when cluttered with data, some maintenance must be performed on a recurrent basis. Instead of keeping all the data content in Geoserver’ memory, existing content is moved to a secondary location on the filesystem daily through a script running as a cronjob. Reloading the products to Geoserver is performed on-demand by the user through a set of Perl and Python scripts, initiated by client request performed on the front-end. This strategy allows for a considerable performance increase in data access and gives the best priority of access to today’s flood predictions.

The front-end consists of a single-page responsive web application which allows users to visualize all the products served by the back-end, in an intuitive interface available for multiple devices. With the goal of ubiquitousness in mind, less-intensive technologies were chosen: 1) HTML5 and CSS3, as the building base of all web-applications, 2) AngularJS, a javascript framework that offers dynamic templating and two-way databinding, 3) Google Polymer, a Google design specification implementation library, and 4) OpenLayers, a library for handling geospatial data and mapping tools on the client-side. Although some technologies, like AngularJS and Google Polymer, are still in a beta stage, they are supported and maintained by Google and have a huge community contributing for their development (AngularJS has over 6K commits on github, more than older and well-known javascript libraries such as JQuery with less than 6K commits). Using these technologies appears thus a good choice for future developments, since they shape the way we build the web (www.polymer-project.org) and fully fulfill the user requirements.

As referred before, the front-end maintains communication with the back-end via a set of REST services made available by the back-end. Responses to these request come in JSON, a lightweight data-interchange format easy to read/write by humans and to parse/create by machines.

The server-side information flow system has been planned and built to easily gather real-time data from the wireless sensor network, to parse the relevant information and store it

in a persistent database system, to use the measurements to run forecasting models, and to provide the forecast results to the end-user. A detailed description of this flow of information can be seen in Fig. 2. From top to bottom, this system building blocks are 1) a wireless sensor network (WSN), comprised of several sensor nodes; 2) a data gathering server, which communicates with the WSN gathering and parsing real-time data; 3) prediction model instance and corresponding redundancy instance (to guarantee a fallback), that produce forecasting results with real-time data as one of the inputs; 4) several instances of Geoserver (again to guarantee a fallback, but also to guarantee data availability for a great amount of web-requests), that start by consuming forecast results in the form of visual imagery which later renders to the end-user in the form of WMS layers. All the instances of Geoserver are managed by a load-balancer that decides which instance should handle the client requests. The WSN consists of several real-time station nodes scattered in the domain of interest, which record water level data and transmit it to a central server. This central server is basically a set of scripts that trigger the transmission via either GPRS into an FTP server or Circuit Switched Data (CSD) directly into the file system. After the transmission is performed successfully, data is handled by the central-server to parse and store it, and to create input files for the prediction models. On their side, prediction models produce water level forecast results for the next 48 hours which are then consumed by the geographical web server. Geoserver accepts both raster images (geotiff) and vector files (shapefiles), but can also produce images from Postgis database data. These images are georeferenced and then presented in the user interface on a layer map.

IV. APPLICATION TO THE CASE STUDY

The flexibility and usefulness of the platform is illustrated here, applied to the MOLINES case study, mainly through examples of the functionalities available on the interface. For this project, the requirements were the following: 1) the platform would account for different user roles, providing differentiated access to dedicated products; 2) the platform should be able to host georeferenced products from the static risk analysis (hazard, vulnerability) and the dynamic real time forecast; 3) the platform should be agile, providing fast access to the alerts and their products; and 4) the platform should be prepared to incorporate and show in a georeferenced way the information uploaded by the civil protection agents in the field during emergencies.

This application user interface is composed of a top header with title, a sidebar for displaying the various links to the main functionalities offered and a detailed content area. The sidebar hides when opening the application in smaller devices (smartphones or tablets), and is accessible by a button on the top header, as seen in Fig. 3. This allows the main content to be shown in full screen, taking advantage of all available space on the device screen.

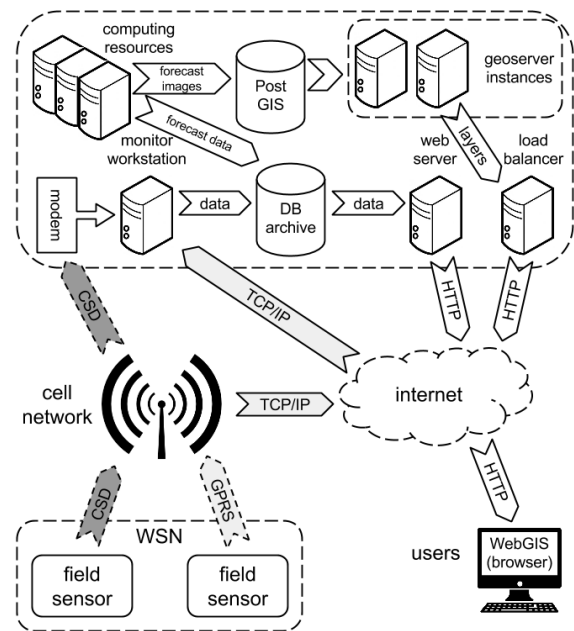

Fig. 2 Network information data flow

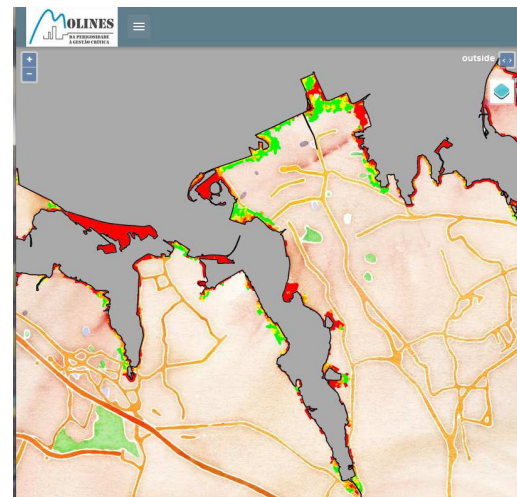

Fig. 3 Example of the interface adapted to a mobile device

Since this is a platform for support of detailed risk management, it must provide the users with multiple ways to access all the risk events detected: a quick way, through both geographical representation of a specific area and a short list of areas, and a very detailed listing, supported by clear identification of the most vulnerable locations. This functionality can be seen in a) Fig. 4: a summary of study zones and risk alerts triggered for each zone as well as their risk type, b) Fig. 5: a detailed listing of locations at risk and the alert bulletins. Also, when hovering over the zones on the table in Fig. 4, the corresponding zone on the map gets highlighted for a better notion of where this zone is and provides a direct link to the detailed listing of Fig. 5. Similarly, each zone name is a link for the more detailed description of the risk events occurring at that specific zone.



Fig. 4 Summary of risk events

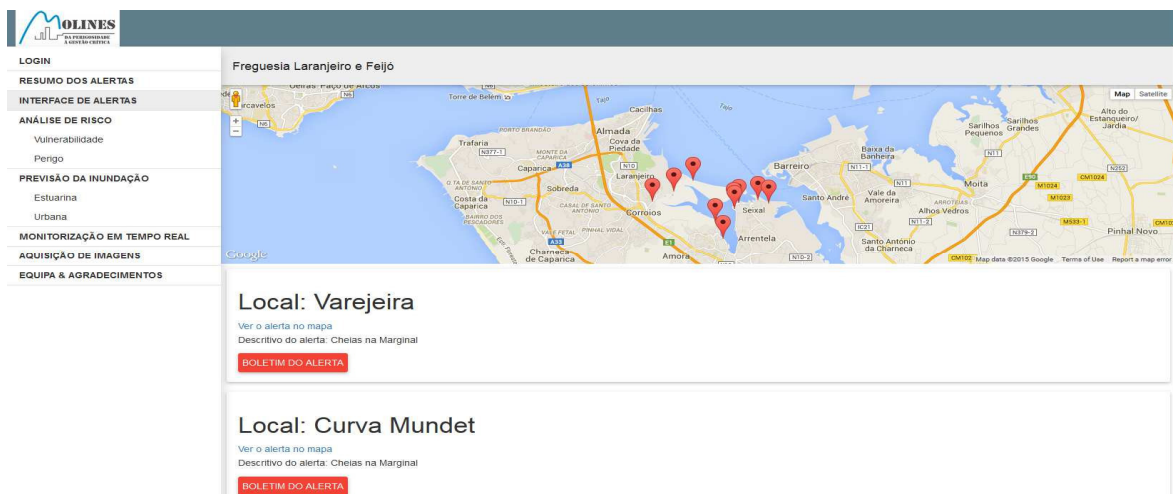

Fig. 5 Detailed location of areas at risk

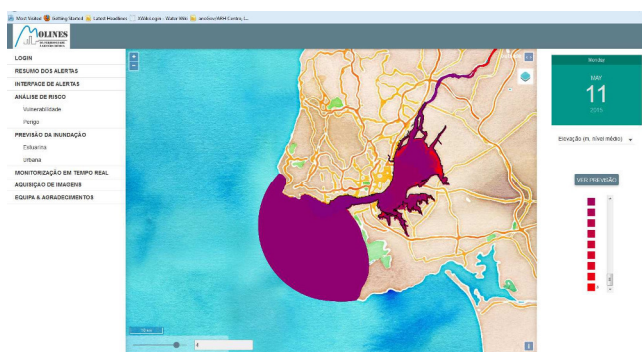

Fig. 6 Water level forecast

Other functionalities include a section to provide access to the real-time data gathered from WSN, which also allows an automatic comparison with model forecast results. This functionality allows the end-users to access data being measured at a point of interest but also to validate model predictions with real-time data. Indeed, this comparison is fundamental for the emergency agents and other decision-

makers to provide them a measure of reliability on the model predictions and confidence on the actions to be promoted in the field.

V.DISCUSSION AND FUTURE WORK

Herein, an interactive, flexible and multiple user roles Web platform is presented, which takes advantage of novel technologies to provide fast access to all relevant online, intuitive and geographically referenced real-time data and model predictions for urban and estuarine floods.

Future work on the platform is planned to further improve its performance. For instance, one of the strategies includes using GeoJSON, an open standard format for encoding geographical information features using Javascript Object Notation, on the client-side to render georeferenced data layers on top of maps, instead of depending on Geoserver to serve those layers. This would put the workload on the client-side instead of the server-side, which would produce faster results overall.

At the same time, the overall goal of these IT platforms is to have them integrated in the everyday's workflow of end-users. Their operation requires considerable computational efforts that may not be available in many decision-makers IT infrastructures. As LNEC's computational resources are finite and often related with on-going scientific projects, a solution should be looked up to provide the best solution for end-users. In order to allow for stakeholders to run their own prediction model instances and operate these IT platforms, future work also includes the creation of prediction model deployments on the cloud.

For the MOLINES application, the future work will be concentrated on the integration, in the interface, of the uploaded data provided by the agents in the field. Challenges are the automatic check on the reliability of this information and the way to integrate them in the interface in a simple and easy to probe manner. Other add-ons include also the issuing of the alert based on the model predictions.

VI. ACKNOWLEDGMENT

The authors thank Paula Freire and Ana Rilo, from LNEC, Alexandre Tavares and Pedro Santos, from CES, and Luis Sá, from the Portuguese Civil Protection, for helping with the definition of the platform requirements. They also thank the SCHISM community for making their model code available at <http://ccrm.vims.edu/schism/>.

REFERENCES

- [1] Townend, I. and Pethick, J. (2002) Estuarine flooding and managed retreat. *Society* (2002), Volume: 360, Issue: 1796, pp. 1477-1495. DOI: 10.1098/rsta.2002.1011
- [2] Ugarelli, R., Leitão, J.P., Almeida, M.C., Bruaset, S. (2011) Overview of climate change effects which may impact the urban water cycle (PREPARED 2011.011 report). PREPARED: enabling change project.
- [3] Jesus, G., Oliveira, A., Santos, M.A. and Palha-Fernandes, J. (2010) – Development of a Dam-break Flood Emergency System, Proceedings of the 7th International ISCRAM Conference, pp. 5.
- [4] Pradhan, A.R., D.F. Laefer and W.J. Rasdorf (2007). Infrastructure Management Information system framework requirements for disasters, *Journal of Computing in Civil Engineering*, March-April, pp. 90-101. DOI: 10.1061/(ASCE)0887-3801(2007)21:2(90)
- [5] Carracedo, P., et al. (2006) Improvement of pollutant drift forecast system applied to the Prestige oil spills in Galicia Coast (NW of Spain): Development of an operational system. *Marine Pollution Bulletin* 53(5-7) pp. 350-360. DOI:10.1016/j.marpolbul.2005.11.014
- [6] Rodrigues M., et al. (2013) Application of an estuarine and coastal nowcast-forecast information system to the Tagus estuary. Proceedings of the 6th SCACR – International Short Course/Conference on Applied Coastal Research (Lisboa, Portugal), pp.10.
- [7] Oliveira, A., et al. (2014) An interactive WebGIS observatory platform for enhanced support of coastal management. *Journal of Coastal Research*, Special Issue No. 66, , ISSN 0749-0208, pp. 507-512
- [8] Deng Z. Q. Namwamba, F., Zhang, Z.H. (2014) Development of decision support system for managing and using recreational beaches, *Journal of Hydroinformatics*, Volume: 16, Issue: 2, pp. 447-457. DOI:10.2166/hydro.2013.185
- [9] Rinaldi, S., Peerenboom, J., and Kelly, T. (2001) Complexities in Identifying, Understanding, and Analyzing Critical Infrastructure Interdependencies, *IEEE Control Systems Magazine*, pp. 11-25. DOI: 10.1109/37.969131
- [10] Corbacioglu, S. and Kapucu, N. (2006) Organizational Learning and Self-adaptation in Dynamic Disaster Environments, *Disasters*, 30, 2, pp. 212-233. DOI: 10.1111/j.0361-3666.2006.00316.x
- [11] Beroggi, G.E.G. and Wallace, W.A. (1994) Operational Risk Management: A New Paradigm for Decision Making. *IEEE Transactions on Systems, Man, and Cybernetics*, 24, pp. 1450-1457. DOI: 10.1109/21.310528
- [12] Beroggi, G.E.G. and Wallace, W.A. (2000) Multi-Expert Operational Risk Management, *IEEE Transactions on Systems, Man and Cybernetics Part C* 30, pp. 32-44. DOI: 10.1109/5326.827452
- [13] Marincioni, F. (2007) Information Technologies and The Sharing of Disaster Knowledge: The Critical Role of Professional Culture, *Disasters*, 31, 4, pp. 459–476. DOI: 10.1111/j.1467-7717.2007.01019.x
- [14] Kyng, M., Nielsen, E. T. and Kristensen, M. (2006) Challenges in designing interactive systems for emergency response. In Proceedings of the 6th ACM Conference on Designing interactive Systems ACM Press, pp. 301-310. DOI: 10.1145/1142405.1142450
- [15] Herold, S., M. Sawada, B. Wellar. (2005) Integrating geographic information systems, spatial databases and the internet: a framework for disaster management. Proceedings of the 98 th Annual Canadian Institute of Geomatics Conference, pp. 13-15.
- [16] Fahland, D., Gläber, T.M., Quilitz, B., Weibleder, S. & Leser, U., HUODINI – Flexible Information Integration for Disaster Management, Proceedings ISCRAM2007, 2007, pp. 255-138.
- [17] Kulkarni, A. T., et al. (2014) "A web GIS based integrated flood assessment modeling tool for coastal urban watersheds." *Computers & Geosciences* 64: pp. 7-14. DOI: 10.1016/j.cageo.2013.11.002